

## ABSTRACT PHYSICAL TRACES

SAMSON ABRAMSKY AND BOB COECKE

ABSTRACT. We revise our ‘Physical Traces’ paper [Abramsky and Coecke CTCS’02] in the light of the results in [Abramsky and Coecke LiCS’04]. The key fact is that the notion of a *strongly compact closed category* allows abstract notions of adjoint, bipartite projector and inner product to be defined, and their key properties to be proved. In this paper we improve on the definition of strong compact closure as compared to the one presented in [Abramsky and Coecke LiCS’04]. This modification enables an elegant characterization of strong compact closure in terms of adjoints and a Yanking axiom, and a better treatment of bipartite projectors.

### 1. Introduction

In [Abramsky and Coecke CTCS’02] we showed that vector space *projectors*

$$P : V \otimes W \rightarrow V \otimes W$$

which have a one-dimensional subspace of  $V \otimes W$  as fixed-points, suffice to implement any linear map, and also the categorical trace [Joyal, Street and Verity 1996] of the category  $(\mathbf{FdVec}_{\mathbb{K}}, \otimes)$  of finite-dimensional vector spaces and linear maps over a base field  $\mathbb{K}$ . The interest of this is that projectors of this kind arise naturally in quantum mechanics (for  $\mathbb{K} = \mathbb{C}$ ), and play a key role in information protocols such as *quantum teleportation* [Bennett et al. 1993] and *entanglement swapping* [Żukowski et al. 1993], and also in measurement-based schemes for quantum computation. We showed how both the category  $(\mathbf{FdHilb}, \otimes)$  of finite-dimensional complex Hilbert spaces and linear maps, and the category  $(\mathbf{Rel}, \times)$  of relations with the cartesian product as tensor, can be physically realized in this sense.

In [Abramsky and Coecke LiCS’04] we showed that such projectors can be defined, and their crucial properties proved, at the abstract level of *strongly compact closed categories*. This categorical structure is a major ingredient of the categorical axiomatization in [Abramsky and Coecke LiCS’04] of quantum theory [von Neumann 1932]. It captures quantum entanglement and its behavioural properties [Coecke 2003]. In this paper we will improve on the definition of strong compact closure, enabling a characterization in terms of adjoints — in the linear algebra sense, suitably abstracted — and Yanking, without explicit reference to compact closure, and enabling a nicer treatment of bipartite projectors, coherent with the treatment of arbitrary projectors in [Abramsky and Coecke LiCS’04].

---

Rick Blute, Sam Braunstein, Vincent Danos, Martin Hyland and Prakash Panangaden provided useful feed-back. This research was supported by the EPSRC grant EP/C500032/1.

Received by the editors 2004-01-12 and, in revised form, 2005-01-12.

Transmitted by R. Blute. Published on 2005-03-29.

2000 Mathematics Subject Classification: 15A04,15A90,18B10,18C50,18D10,81P10,81P68.

© Samson Abramsky and Bob Coecke, 2004. Permission to copy for private use granted.

We are then able to show that the constructions in [Abramsky and Coecke CTCS'02] for realizing arbitrary morphisms and the trace by projectors carry over to the abstract level, and that these constructions admit an information-flow interpretation in the spirit of additive or ‘particle-style’ traces [Abramsky 1996, Abramsky, Haghverdi and Scott 2002]. It is the information flow due to (strong) compact closure which is crucial for the abstract formulation, and for the proofs of correctness of protocols such as quantum teleportation [Abramsky and Coecke LiCS'04].

A concise presentation of (very) basic quantum mechanics which supports the developments in this paper can be found in [Abramsky and Coecke CTCS'02, Coecke 2003]. However, the reader with a sufficient categorical background might find the abstract presentation in [Abramsky and Coecke LiCS'04] more enlightening.

## 2. Strongly compact closed categories

As shown in [Kelly and Laplaza 1980], in any monoidal category  $\mathbf{C}$ , the endomorphism monoid  $\mathbf{C}(I, I)$  is commutative. Furthermore any  $s : I \rightarrow I$  induces a natural transformation

$$s_A : A \xrightarrow{\simeq} I \otimes A \xrightarrow{s \otimes 1_A} I \otimes A \xrightarrow{\simeq} A.$$

Hence, setting  $s \bullet f$  for  $f \circ s_A = s_B \circ f$  for  $f : A \rightarrow B$ , we have

$$(s \bullet g) \circ (r \bullet f) = (s \circ r) \bullet (g \circ f)$$

for  $r : I \rightarrow I$  and  $g : B \rightarrow C$ . We call the morphisms  $s \in \mathbf{C}(I, I)$  *scalars* and  $s \bullet -$  *scalar multiplication*. In  $(\mathbf{FdVec}_{\mathbb{K}}, \otimes)$ , linear maps  $s : \mathbb{K} \rightarrow \mathbb{K}$  are uniquely determined by the image of 1, and hence correspond biuniquely to elements of  $\mathbb{K}$ . In  $(\mathbf{Rel}, \times)$ , there are just two scalars, corresponding to the Booleans  $\mathbb{B}$ .

Recall from [Kelly and Laplaza 1980] that a *compact closed category* is a symmetric monoidal category  $\mathbf{C}$ , in which, when  $\mathbf{C}$  is viewed as a one-object bicategory, every one-cell  $A$  has a left adjoint  $A^*$ . Explicitly this means that for each object  $A$  of  $\mathbf{C}$  there exists a *dual object*  $A^*$ , a *unit*  $\eta_A : I \rightarrow A^* \otimes A$  and a *counit*  $\epsilon_A : A \otimes A^* \rightarrow I$ , and that the diagrams

$$\begin{array}{ccccc}
 A & \xrightarrow{\simeq} & A \otimes I & \xrightarrow{1_A \otimes \eta_A} & A \otimes (A^* \otimes A) \\
 \downarrow 1_A & & & & \downarrow \simeq \\
 A & \xleftarrow{\simeq} & I \otimes A & \xleftarrow{\epsilon_A \otimes 1_A} & (A \otimes A^*) \otimes A
 \end{array} \tag{1}$$

and

$$\begin{array}{ccc}
 A^* & \xrightarrow{\simeq} & I \otimes A^* \xrightarrow{\eta_A \otimes 1_{A^*}} (A^* \otimes A) \otimes A^* \\
 \downarrow 1_{A^*} & & \downarrow \simeq \\
 A^* & \xleftarrow{\simeq} & A^* \otimes I \xleftarrow{1_{A^*} \otimes \epsilon_A} A^* \otimes (A \otimes A^*)
 \end{array} \tag{2}$$

both commute. Alternatively, a compact closed category may be defined as a  $*$ -autonomous category [Barr 1979] with a self-dual tensor, hence a ‘degenerate’ model of linear logic [Seely 1998].

For each morphism  $f : A \rightarrow B$  in a compact closed category we can define a *dual*  $f^*$ , a *name*  $\ulcorner f \urcorner$  and a *coname*  $\lrcorner f \lrcorner$ , respectively as

$$\begin{array}{ccc}
 B^* & \xrightarrow{\simeq} & I \otimes B^* \xrightarrow{\eta_A \otimes 1_{B^*}} A^* \otimes A \otimes B^* \\
 \downarrow f^* & & \downarrow 1_{A^*} \otimes f \otimes 1_{B^*} \\
 A^* & \xleftarrow{\simeq} & A^* \otimes I \xleftarrow{1_{A^*} \otimes \epsilon_B} A^* \otimes B \otimes B^*
 \end{array}$$
  

$$\begin{array}{ccc}
 A^* \otimes A & \xrightarrow{1_{A^*} \otimes f} & A^* \otimes B \\
 \uparrow \eta_A & \nearrow \ulcorner f \urcorner & \\
 I & & \\
 & & \nearrow \lrcorner f \lrcorner \\
 & & A \otimes B^* \xrightarrow{f \otimes 1_{B^*}} B \otimes B^* \\
 & & \uparrow \epsilon_B \\
 & & I
 \end{array}$$

In particular, the assignment  $f \mapsto f^*$  extends  $A \mapsto A^*$  into a contravariant endofunctor with  $A \simeq A^{**}$ . In any compact closed category, we have

$$\mathbf{C}(A \otimes B^*, I) \simeq \mathbf{C}(A, B) \simeq \mathbf{C}(I, A^* \otimes B),$$

so ‘elements’ of  $A \otimes B$  are in biunique correspondence with names/conames of morphisms  $f : A \rightarrow B$

Typical examples are **(Rel,  $\times$ )** where  $X^* = X$  and where for  $R \subseteq X \times Y$ ,

$$\ulcorner R \urcorner = \{(*, (x, y)) \mid xRy, x \in X, y \in Y\}$$

$$\lrcorner R \lrcorner = \{((x, y), *) \mid xRy, x \in X, y \in Y\}$$

and, **(FdVec $_{\mathbb{K}}$ ,  $\otimes$ )** where  $V^*$  is the dual vector space of linear functionals  $v : V \rightarrow \mathbb{K}$  and where for  $f : V \rightarrow W$  with matrix  $(m_{ij})$  in bases  $\{e_i^V\}_{i=1}^n$  and  $\{e_j^W\}_{j=1}^m$  of  $V$  and  $W$

respectively we have

$$\begin{aligned} \lceil f \rceil : \mathbb{K} &\rightarrow V^* \otimes W :: 1 \mapsto \sum_{\substack{i,j=1 \\ i,j=n,m}} m_{ij} \cdot \bar{e}_i^V \otimes e_j^W \\ \lfloor f \rfloor : V \otimes W^* &\rightarrow \mathbb{K} :: e_i^V \otimes \bar{e}_j^W \mapsto m_{ij}. \end{aligned}$$

where  $\{\bar{e}_i^V\}_{i=1}^{i=n}$  is the base of  $V^*$  satisfying  $\bar{e}_i^V(e_j^V) = \delta_{ij}$ , and similarly for  $W$ . Another example is the category  $n\mathbf{Cob}$  of  $n$ -dimensional *cobordisms*, which is a basic ingredient of Topological Quantum Field Theories in mathematical physics, see e.g. [Baez 2004].

Each compact closed category admits a categorical trace, that is, for every morphism  $f : A \otimes C \rightarrow B \otimes C$  a trace  $\mathrm{Tr}_{A,B}^C(f) : A \rightarrow B$  is specified and satisfies certain axioms [Joyal, Street and Verity 1996]. Indeed, we can set

$$\mathrm{Tr}_{A,B}^C(f) := \rho_B^{-1} \circ (1_B \otimes \epsilon_C) \circ (f \circ 1_{C^*}) \circ (1_A \otimes (\sigma_{C^*,C} \circ \eta_C)) \circ \rho_A \quad (3)$$

where  $\rho_X : X \simeq X \otimes I$  and  $\sigma_{X,Y} : X \otimes Y \simeq Y \otimes X$ . In  $(\mathbf{Rel}, \times)$  this yields

$$x \mathrm{Tr}_{X,Y}^Z(R)y \Leftrightarrow \exists z \in Z. (x, z)R(y, z)$$

for  $R \subseteq (X \times Z) \times (Y \times Z)$  while in  $(\mathbf{FdVec}_{\mathbb{K}}, \otimes)$  we obtain

$$\mathrm{Tr}_{V,W}^U(f) : e_i^V \mapsto \sum_{\alpha} m_{i\alpha j\alpha} e_j^W$$

where  $(m_{ikjl})$  is the matrix of  $f$  in bases  $\{e_i^V \otimes e_k^U\}_{ik}$  and  $\{e_j^W \otimes e_l^U\}_{jl}$ .

**2.1. DEFINITION.** [Strong Compact Closure I] A *strongly compact closed category* is a compact closed category  $\mathbf{C}$  in which  $A = A^{**}$  and  $(A \otimes B)^* = A^* \otimes B^*$ , and which comes together with an involutive covariant compact closed functor  $(\ )_* : \mathbf{C} \rightarrow \mathbf{C}$  which assigns to each object  $A$  its dual  $A^*$ .

So in a strongly compact closed category we have two involutive functors, namely a contravariant one  $(\ )^* : \mathbf{C} \rightarrow \mathbf{C}$  and a covariant one  $(\ )_* : \mathbf{C} \rightarrow \mathbf{C}$  which coincide in their action on objects. Recall from [Kelly and Laplaza 1980] that  $(\ )_*$  being a *compact closed functor* means that it preserves the monoidal structure strictly, and also the unit and counit, *i.e.*

$$\lceil 1_{A_*} \rceil = (\lceil 1_A \rceil)_* \circ u_I^{-1} \quad \text{and} \quad \lfloor 1_{A_*} \rfloor = u_I \circ (\lfloor 1_A \rfloor)_* \quad (4)$$

where  $u_I : I^* \simeq I$ . This in particular implies that  $(\ )_*$  commutes with  $(\ )^*$  since  $(\ )^*$  is definable in terms of the monoidal structure,  $\eta$  and  $\epsilon$  — in [Abramsky and Coecke LiCS'04] we only assumed commutation of  $(\ )_*$  and  $(\ )^*$  instead of the stronger requirement of equations (4).

For each morphism  $f : A \rightarrow B$  in a strongly compact closed category we can define an *adjoint* — as in linear algebra — as

$$f^\dagger := (f_*)^* = (f^*)_* : B \rightarrow A.$$

It turns out that we can also define strong compact closure by taking the adjoint to be a primitive.

2.2. THEOREM. [Strong Compact Closure II] *A strongly compact closed category can be equivalently defined as a symmetric monoidal category  $\mathbf{C}$  which comes with*

1. *A monoidal involutive assignment  $A \mapsto A^*$  on objects.*
2. *An identity-on-objects, contravariant, strict monoidal, involutive functor  $f \mapsto f^\dagger$ .*
3. *For each object  $A$  a unit  $\eta_A : I \rightarrow A^* \otimes A$  with  $\eta_{A^*} = \sigma_{A^*,A} \circ \eta_A$  and such that either the diagram*

$$\begin{array}{ccccc}
 A & \xrightarrow{\simeq} & A \otimes I & \xrightarrow{1_A \otimes \eta_A} & A \otimes (A^* \otimes A) \\
 \downarrow 1_A & & & & \downarrow \simeq \\
 A & \xleftarrow{\simeq} & I \otimes A & \xleftarrow{(\eta_A^\dagger \circ \sigma_{A,A^*}) \otimes 1_A} & (A \otimes A^*) \otimes A
 \end{array} \tag{5}$$

or the diagram

$$\begin{array}{ccccccc}
 A & \xrightarrow{\simeq} & I \otimes A & \xrightarrow{\eta_A \otimes 1_A} & (A^* \otimes A) \otimes A & \xrightarrow{\simeq} & A^* \otimes (A \otimes A) \\
 \downarrow 1_A & & & & & & \downarrow 1_{A^*} \otimes \sigma_{A,A} \\
 A & \xleftarrow{\simeq} & I \otimes A & \xleftarrow{\eta_A^\dagger \otimes 1_A} & (A^* \otimes A) \otimes A & \xleftarrow{\simeq} & A^* \otimes (A \otimes A)
 \end{array} \tag{6}$$

commutes, where  $\sigma_{A,A} : A \otimes A \simeq A \otimes A$  is the twist map.

4. *Given such a functor  $(\ )^\dagger$ , we define an isomorphism  $\alpha$  to be unitary if  $\alpha^{-1} = \alpha^\dagger$ . We additionally require that the canonical natural isomorphisms for associativity, unit and symmetry given as part of the symmetric monoidal structure on  $\mathbf{C}$  are (componentwise) unitary in this sense.<sup>1</sup>*

While diagram (5) is the analogue to diagram (1) with  $\eta_A^\dagger \circ \sigma_{A,A^*}$  playing the role of the coname, diagram (6) expresses *yanking* with respect to the canonical trace of the

<sup>1</sup>This stipulation is in fact also needed in the first definition of strong compact closure. Note also that, for simplicity, we take the assignment  $(\ )^*$  on objects to be *strictly* monoidal, that is, satisfying the equations (i)  $(A \otimes B)^* = A^* \otimes B^*$  and (ii)  $I^* = I$ . While the first of these is actually satisfied in  $(\mathbf{FdHilb}, \otimes)$ , taking  $(\ )^*$  to be conjugation as in the ensuing discussion, the second is not. There is always an explicitly definable isomorphism  $u : I \simeq I^*$  in any compact closed category. If we drop equation (ii), we must add the requirement that  $\eta_I^\dagger \circ \eta_I = 1_I$ , i.e. that the unit object has dimension 1. This ensures that  $u$  is unitary.

compact closed structure. We only need one commuting diagram as compared to diagrams (1) and (2) in the definition of compact closure and hence in Definition 2.1 since due to the strictness assumption (i.e.  $A \mapsto A^*$  being involutive) we were able to replace the second diagram by  $\eta_{A^*} = \sigma_{A^*,A} \circ \eta_A$ . Note that now  $f_* := (f^\dagger)^* = (f^*)^\dagger$ .

Returning to the main issue of this paper, we are now able to construct a *bipartite projector* (i.e. a projector on an object of type  $A \otimes B$ ) as

$$P_f := \ulcorner f^\neg \circ (\ulcorner f^\neg)^\dagger = \ulcorner f^\neg \circ \lrcorner f_{* \lrcorner} : A^* \otimes B \rightarrow A^* \otimes B,$$

that is, we have an assignment

$$P_- : \mathbf{C}(\mathbf{I}, A^* \otimes B) \longrightarrow \mathbf{C}(A^* \otimes B, A^* \otimes B) :: \Psi \mapsto \Psi \circ \Psi^\dagger$$

from bipartite elements to bipartite projectors. Note that the use of  $(\ )_*$  is essential in order for  $P_f$  to be endomorphic.

We can *normalize* these projectors  $P_f$  by considering  $s_f \bullet P_f$  for  $s_f := (\lrcorner f_{* \lrcorner} \circ \ulcorner f^\neg)^{-1}$  (provided this inverse exists in  $\mathbf{C}(\mathbf{I}, \mathbf{I})$ ), yielding

$$(s_f \bullet P_f) \circ (s_f \bullet P_f) = s_f \bullet (\ulcorner f^\neg \circ (s_f \bullet (\lrcorner f_{* \lrcorner} \circ \ulcorner f^\neg)) \circ \lrcorner f_{* \lrcorner}) = s_f \bullet P_f,$$

and also

$$(s_f \bullet P_f) \circ \ulcorner f^\neg = \ulcorner f^\neg \quad \text{and} \quad \lrcorner f_{* \lrcorner} \circ (s_f \bullet P_f) = \lrcorner f_{* \lrcorner}.$$

Any compact closed category in which  $(\ )^*$  is the identity on objects is trivially strongly compact closed. Examples include relations and finite-dimensional real inner-product spaces, and also the interaction category **SProc** from [Abramsky 1995].

So, importantly — and less trivially —, is the category **(FdHilb,  $\otimes$ )** of finite-dimensional *complex* Hilbert spaces and linear maps. We take  $\mathcal{H}^*$  to be the *conjugate space*, that is, the Hilbert space with the same elements as  $\mathcal{H}$  but with the scalar multiplication and the inner-product in  $\mathcal{H}^*$  defined by

$$\alpha \bullet_{\mathcal{H}^*} \phi := \bar{\alpha} \bullet_{\mathcal{H}} \phi \quad \langle \phi \mid \psi \rangle_{\mathcal{H}^*} := \langle \psi \mid \phi \rangle_{\mathcal{H}},$$

where  $\bar{\alpha}$  is the complex conjugate of  $\alpha$ . Hence we can still take  $\epsilon_{\mathcal{H}}$  to be the *sesquilinear* inner-product.

Conversely, an *abstract notion of inner product* can be defined in any strongly compact closed category. Given ‘elements’  $\psi, \phi : \mathbf{I} \rightarrow A$ , we define

$$\langle \psi \mid \phi \rangle := \psi^\dagger \circ \phi \in \mathbf{C}(\mathbf{I}, \mathbf{I}).$$

As an example, the inner-product in **(Rel,  $\times$ )** is, for  $x, y \subseteq \{*\} \times X$ ,

$$\langle x \mid y \rangle = 1_{\mathbf{I}} \quad \text{for} \quad x \cap y \neq \emptyset \quad \text{and} \quad \langle x \mid y \rangle = 0_{\mathbf{I}} \quad \text{for} \quad x \cap y = \emptyset$$

with  $1_{\mathbf{I}} := \{*\} \times \{*\} \subseteq \{*\} \times \{*\}$  and  $0_{\mathbf{I}} := \emptyset \subseteq \{*\} \times \{*\}$ . At the abstract level, we can *prove* the defining properties both of inner-product space adjoints and inner-product space unitarity:

$$\langle f^\dagger \circ \psi \mid \phi \rangle_B = (f^\dagger \circ \psi)^\dagger \circ \phi = \psi^\dagger \circ f \circ \phi = \langle \psi \mid f \circ \phi \rangle_A$$

$$\langle U \circ \psi \mid U \circ \varphi \rangle_B = \langle U^\dagger \circ U \circ \psi \mid \varphi \rangle_A = \langle \psi \mid \varphi \rangle_A$$

for  $\psi, \varphi : I \rightarrow A$ ,  $\phi : I \rightarrow B$ ,  $f : B \rightarrow A$  and  $U : A \rightarrow B$ . An alternative way to define the abstract inner-product is

$$I \xrightarrow{\rho_I} I \otimes I \xrightarrow{1_I \otimes u_I} I \otimes I^* \xrightarrow{\phi \otimes \psi_*} A \otimes A^* \xrightarrow{\epsilon_A} I$$

where  $u_I : I \simeq I^*$  and  $\rho_I : I \simeq I \otimes I$  [Abramsky and Coecke LiCS'04]. Here the key data we use is the coname  $\epsilon_A : A \otimes A^* \rightarrow I$ , and also  $(\ )_*$ ; cf. also the above examples of both real and complex inner-product spaces where  $\epsilon_A := \langle - \mid - \rangle$ . Hence it is fair to say that

$$\frac{\text{strong compact closure}}{\text{compact closure}} \simeq \frac{\text{inner-product space}}{\text{vector space}}.$$

Finally, note that abstract bipartite projectors  $P_f$  have two components: a ‘name’-component and a ‘coname’-component. While in most algebraic treatments involving projectors these are taken to be primitive, in our setting projectors are composite entities, and this decomposition will carry over to their crucial properties (see below). We depict names, conames, and projectors as follows:

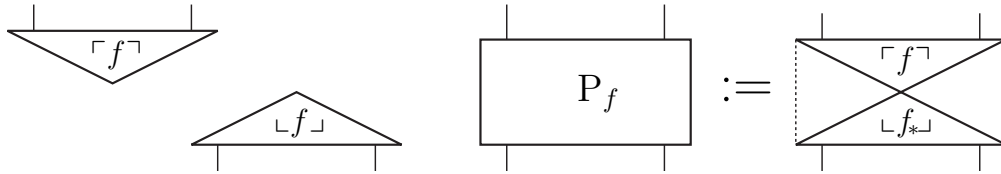

In this representation, diagrams (1) and (6) can be expressed by pictures respectively as

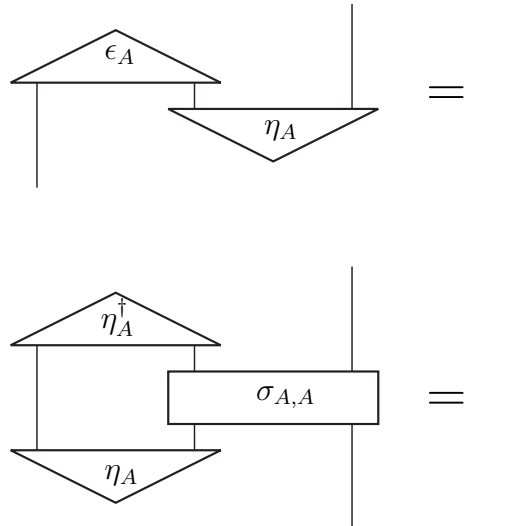

where the vertical lines are identities and  $\epsilon_A := \eta_A^\dagger \circ \sigma_{A,A^*}$ .

### 3. Information-flow through projectors

3.1. LEMMA. [Compositionality - Abramsky and Coecke LiCS'04] *In a compact closed category*

$$\lambda_C^{-1} \circ (\lrcorner f \lrcorner \otimes 1_C) \circ (1_A \otimes \lrcorner g \lrcorner) \circ \rho_A = g \circ f$$

for  $A \xrightarrow{f} B \xrightarrow{g} C$ ,  $\rho_A : A \simeq A \otimes I$  and  $\lambda_C : C \simeq I \otimes C$ , i.e.,

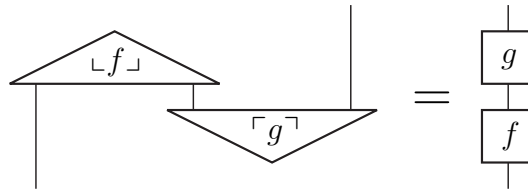

in our graphical representation.

Following [Abramsky and Coecke LiCS'04, Coecke 2003] we can think of the information flowing along the grey line in the diagram below, being acted on by the morphisms which label the coname and the name respectively.

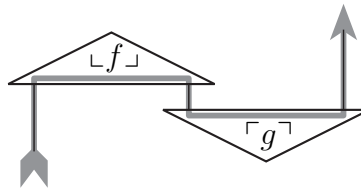

We refer to this as the *information-flow interpretation of compact closure*. Many variants can also be derived [Abramsky and Coecke LiCS'04, Coecke 2003]. The pictures expressing the diagrams (1) and (6) become

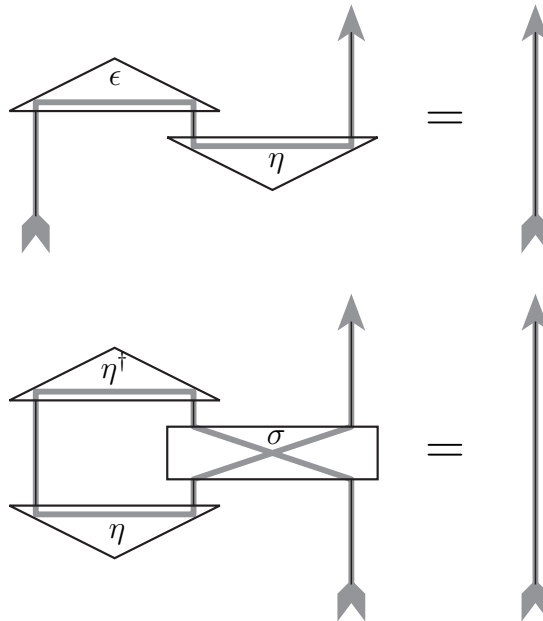



Geometrically, this just says that the line can be ‘yanked straight’.

Lemma 2 of [Abramsky and Coecke CTCS’02], which states that we can realize any linear map  $g : V \rightarrow W$  using only  $(\mathbf{FdHilb}, \otimes)$ -projectors, follows trivially by setting  $f := 1_V$  while viewing both  $\lrcorner 1_V \lrcorner$  and  $\ulcorner g \urcorner$  as being parts of projectors — all this is up to a scalar multiple which depends on the input of  $P_g$ . Note that by functoriality  $1_{V^*} = (1_V)_*$  and hence  $P_{(1_V)_*} = P_{1_{V^*}}$ . As discussed in [Coecke 2003] this feature constitutes the core of *logic-gate teleportation*, which is a fault-tolerant universal quantum computational primitive [Gottesman and Chuang 1999]. Explicitly,

3.2. LEMMA. *In a strongly compact closed category  $\mathbf{C}$  for  $f : A \rightarrow B$ ,*

$$f \otimes (\ulcorner 1_{A^*} \urcorner \circ \lrcorner \xi \lrcorner) = s(f, \xi) \bullet (\sigma_{A,B} \circ (P_{1_{A^*}} \otimes 1_B) \circ (1_A \otimes P_f))$$

where  $s(f, \xi) \in \mathbf{C}(I, I)$  is a scalar,  $\sigma_{A,B} : A \otimes A^* \otimes B \rightarrow B \otimes A^* \otimes A$  is symmetry,  $\xi : A^* \rightarrow B^*$  is arbitrary, and  $s(f, f_*) = 1_I$ .

Lemma 1 of [Abramsky and Coecke CTCS’02], that is, we can realize the  $(\mathbf{FdHilb}, \otimes)$ -trace by means of projectors trivially follows from eq.(3), noting that  $\eta = \ulcorner 1 \urcorner$  and  $\epsilon = \lrcorner 1 \lrcorner$  and again viewing these as parts of projectors. Explicitly:

3.3. LEMMA. *In a strongly compact closed category  $\mathbf{C}$  for  $f : A \otimes C \rightarrow B \otimes C$ ,*

$$\text{Tr}_{A,B}^C(f) \otimes (\ulcorner 1_{C^*} \urcorner \circ \lrcorner \xi \lrcorner) = s(\xi) \bullet ((1_A \otimes P_{1_{C^*}}) \circ (f \otimes 1_{C^*}) \circ (1_B \otimes P_{1_{C^*}}))$$

where  $s(\xi) \in \mathbf{C}(I, I)$  is a scalar,  $\xi : C \rightarrow C$  is arbitrary, and  $s(1_C) = 1_I$ .

Indeed, since  $\sigma_{A^*,A} \circ \ulcorner 1_A \urcorner = \ulcorner (1_A)^* \urcorner = \ulcorner 1_{A^*} \urcorner$  by functoriality, eq.(3) is

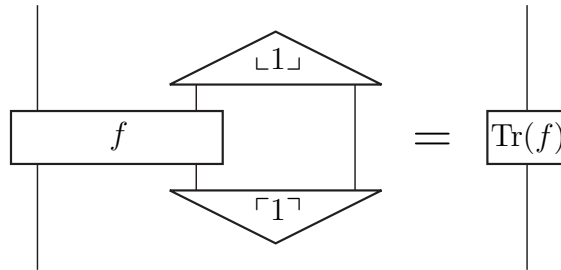

Interestingly, using the information-flow interpretation of compact closure, provided  $f$  itself admits an information-flow interpretation, this construction admits one too, and can be regarded as a feed-back construction. As an example, for  $f := (g_1 \otimes g_2) \circ \sigma \circ (f_1 \otimes f_2)$ , we have (use naturality of  $\sigma$ , the definition of (co)name and compositionality)

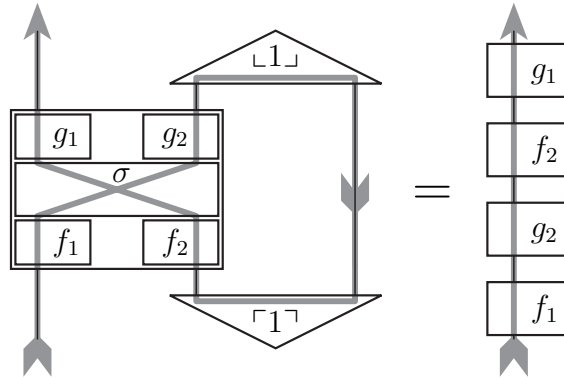

When taking  $f$  itself to be a projector  $P_g = \lceil g \rceil \circ \lfloor g_* \rfloor$  we have

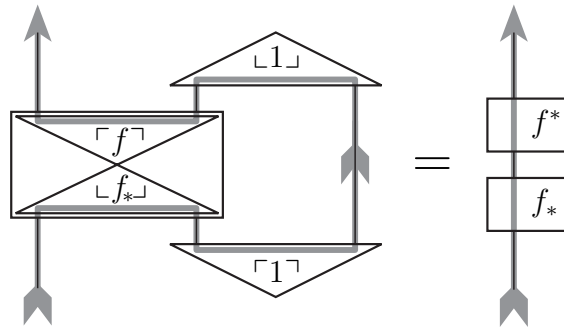

using  $\sigma \circ \lceil f \rceil = \lceil f^* \rceil$ , naturality of  $\sigma$  and compositionality. Note that the information-flow in the loop is in this case ‘forward’ as compared to ‘backward’ in the previous example. For  $f$  of type  $A \otimes (C_1 \otimes \dots \otimes C_n) \rightarrow B \otimes (C_1 \otimes \dots \otimes C_n)$  we can have multiple looping:

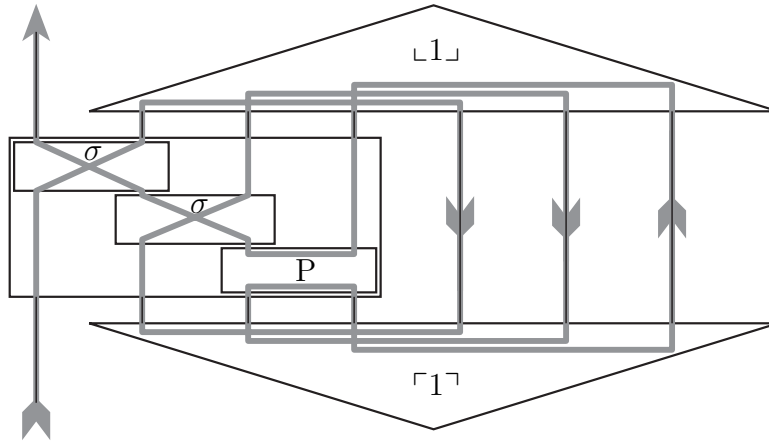

Note the resemblance between this behavior and that of *additive traces* [Abramsky 1996, Abramsky, Haghverdi and Scott 2002] such as the one on  $(\mathbf{Rel}, +)$  namely

$$x \text{Tr}_{X,Y}^Z(R)y \Leftrightarrow \exists z_1, \dots, z_n \in Z. xRz_1R \dots Rz_nRy$$

for  $R \subseteq X + Z \times Y + Z$ . In this case we can think of a particle traveling trough a

network where the elements  $x \in X$  are the possible states of the particle. The morphisms  $R \subseteq X \times Y$  are processes that impose a (non-deterministic) change of state  $x \in X$  to  $y \in R(x)$ , emptiness of  $R(x)$  corresponding to undefinedness. The sum  $X + Y$  is the disjoint union of state sets and  $R + S$  represents parallel composition of processes. The trace  $\text{Tr}_{X,Y}^Z(R)$  is *feedback*, that is, entering in a state  $x \in X$  the particle will either halt, exit at  $y \in Y$  or, exit at  $z_1 \in Z$  in which case it is fed back into  $R$  at the  $Z$  entrance, and so on, until it halts or exits at  $y \in Y$ .

For a more conceptual view of the matter, note that the examples illustrated above all live in the *free compact closed category* generated by a suitable category in the sense of [Kelly and Laplaza 1980]. Indeed our diagrams, which are essentially ‘proof nets for compact closed logic’ [Abramsky and Duncan 2004], give a presentation of this free category. Of course, these diagrams will then have representations in any compact closed category. For a detailed discussion of free constructions for traced and strongly compact closed categories, see the forthcoming paper [Abramsky 2005].

#### 4. (**FRel**, $\times$ , Tr) from (**FdHilb**, $\otimes$ , Tr)

In [Abramsky and Coecke CTCS’02] §3.3 we provided a lax functorial trace-preserving passage from the category (**FdHilb**,  $\otimes$ , Tr) to the category of finite sets and relations (**FRel**,  $\times$ , Tr). This passage involved choosing a base for each Hilbert space. When we restrict the morphisms of **FdHilb** to those for which the matrices in the chosen bases are  $\mathbb{R}^+$ -valued we obtain a true functor.

The results in [Abramsky and Coecke LiCS’04], together with the ideas developed in this paper, provide a better understanding of this passage. In any monoidal category,  $\mathbf{C}(\mathbf{I}, \mathbf{I})$  is an abelian monoid [Kelly and Laplaza 1980] (Prop. 6.1). If  $\mathbf{C}$  has a zero object  $0$  and biproducts  $\mathbf{I} \oplus \dots \oplus \mathbf{I}$  we obtain an abelian semiring with zero  $0_{\mathbf{I}} : \mathbf{I} \rightarrow \mathbf{I}$  and addition  $- + - : \nabla_{\mathbf{I}} \circ (- \oplus -) \circ \Delta_{\mathbf{I}} : \mathbf{I} \rightarrow \mathbf{I}$ . When in such a category every object is isomorphic to one of the form  $\mathbf{I} \oplus \dots \oplus \mathbf{I}$  (finitary), as is the case for both (**FdHilb**,  $\otimes$ ) and (**FRel**,  $\times$ ), then this category is equivalent (as a monoidal category) to the category of  $\mathbf{C}(\mathbf{I}, \mathbf{I})$ -valued matrices with the usual matrix operations. Note that this equivalence involves choosing a basis isomorphism for each object. For (**FdHilb**,  $\otimes$ ) we have  $\mathbf{C}(\mathbf{I}, \mathbf{I}) \simeq \mathbb{C}$  and for (**FRel**,  $\times$ ) we have  $\mathbf{C}(\mathbf{I}, \mathbf{I}) \simeq \mathbb{B}$ , the semiring of booleans. Such a category of matrices is trivially strongly compact closed for  $(\bigoplus_{i=1}^{i=n} \mathbf{I})^* := \bigoplus_{i=1}^{i=n} \mathbf{I}$ ,

$$\eta := (\delta_{i,j})_{i,j} : \mathbf{I} \rightarrow \left( \bigoplus_{i=1}^{i=n} \mathbf{I} \right) \otimes \left( \bigoplus_{j=1}^{j=n} \mathbf{I} \right)$$

(using distributivity and  $\mathbf{I} \otimes \mathbf{I} \simeq \mathbf{I}$ ), and

$$\epsilon : \left( \bigoplus_{i=1}^{i=n} \mathbf{I} \right) \otimes \left( \bigoplus_{i=1}^{i=n} \mathbf{I} \right) \rightarrow \mathbf{I} :: (\psi, \phi) \mapsto \phi^T \circ \psi$$

where  $\phi^T$  denotes the transpose of  $\psi$ . In the case of  $(\mathbf{FRel}, \times)$ , this yields the strong compact closed structure described above. If the abelian semiring  $\mathbf{C}(I, I)$  also admits a non-trivial involution  $(\ )_*$ , an alternative compact closed structure arises by defining  $\epsilon :: (\psi, \phi) \mapsto (\phi^T)_* \circ \psi$ , where  $(\ )_*$  is applied pointwise. The corresponding strong compact closed structure involves defining the adjoint of a matrix  $M$  to be  $(M^T)_*$ , *i.e.* the involution is applied componentwise to the transpose of  $M$ . In this way we obtain (up to categorical equivalence) the strong compact closed structure on  $(\mathbf{FdHilb}, \otimes)$  described above, taking  $(\ )_*$  to be complex conjugation.

Now we can relate trace preserving and (strongly) compact closed functors to (involution preserving) semiring homomorphisms. Any such homomorphism  $h : R \rightarrow S$  lifts to a functor on the categories of matrices. Moreover, such a functor preserves compact closure (and strong compact closure if  $h$  preserves the given involution), and hence also the trace. Clearly there is no semiring embedding  $\xi : \mathbb{B} \rightarrow \mathbb{C}$  since  $\xi(1+1) = \xi(1) \neq \xi(1) + \xi(1)$ . Conversely, for  $\xi : \mathbb{C} \rightarrow \mathbb{B}$  neither  $\xi(-1) \mapsto 0$  nor  $\xi(-1) \mapsto 1$  provide a true homomorphism. But setting  $\xi(c) = 1$  for  $c \neq 0$  we have  $\xi(x+y) \leq \xi(x) + \xi(y)$  and  $\xi(x \cdot y) = \xi(x) \cdot \xi(y)$  which lifts to a *lax* functor —  $\mathbf{FRel}$  is order-enriched, so this makes sense. Restricting from  $\mathbb{C}$  to the abelian semiring  $\mathbb{R}^+$  we obtain a true homomorphism, and hence a compact closed functor.

## References

- Abramsky, S., Gay, S. J. and Nagarajan, R. (1995) *Interaction categories and foundations of typed concurrent programming*. Deductive Program Design: Proceedings of the 1994 Marktoberdorf International Summer School, 35–113, NATO Advanced Science Institutes Series F, Springer-Verlag.
- Abramsky, S. (1996) *Retracing some paths in process algebra*. Proceedings of the Seventh International Conference on Concurrency Theory, LNCS **1119**, 1–17.
- Abramsky, S. (2005) *Abstract Scalars, Loops, and Free Traced and Strongly Compact Closed Categories*. In preparation.
- Abramsky, S. and Coecke, B. (2003) *Physical traces: quantum vs. classical information processing*. Electronic notes on Theoretical Computer Science **69** (CTCS'02 issue). [arXiv:cs/0207057](https://arxiv.org/abs/cs/0207057)
- Abramsky, S. and Coecke, B. (2004) *A categorical semantics of quantum protocols*. Proceedings of the 19th Annual IEEE Symposium on Logic in Computer Science (LiCS'04), IEEE Computer Science Press. (Extended version at [arXiv:quant-ph/0402130](https://arxiv.org/abs/quant-ph/0402130)).
- Abramsky, S. and Coecke, B. (2005) *Abstract quantum mechanics*. In preparation. (Major improvements and additions as compared to [Abramsky and Coecke LiCS'04]).

- Abramsky, S. and Duncan, R. W. (2004) *A categorical quantum logic*. Proceedings of the Second International Workshop on Quantum Programming Languages (QPL 04).
- Abramsky, S., Haghverdi, E. and Scott, P. J. (2002) *Geometry of interaction and linear combinatory algebras*. Mathematical Structures in Computer Science **12**, 625–665.
- Baez, J. (2004) *Quantum quandaries: a category-theoretic perspective*. Structural Foundations of Quantum Gravity, eds. S. French, D. Rickles and J. Sahatsi, Oxford University Press. [arXiv:quant-ph/0404040](https://arxiv.org/abs/quant-ph/0404040)
- Barr, M. (1979) *\*-Autonomous Categories*. Lecture Notes in Mathematics **752**, Springer-Verlag.
- Bennett, C. H., Brassard, C., Crépeau, C., Jozsa, R., Peres, A. and Wootters, W. K. (1993) *Teleporting an unknown quantum state via dual classical and Einstein-Podolsky-Rosen channels*. Physical Review Letters **70**, 1895–1899.
- Coecke, B. (2003) *The logic of entanglement. An invitation*. Research Report PRG-RR-03-12 Oxford University Computing Laboratory. [web.comlab.ox.ac.uk/oucl/publications/tr/rr-03-12.html](http://web.comlab.ox.ac.uk/oucl/publications/tr/rr-03-12.html) (short version at [arXiv:quant-ph/0402014](https://arxiv.org/abs/quant-ph/0402014))
- Gottesman, D. and Chuang, I. L. (1999) *Quantum teleportation is a universal computational primitive*. Nature **402**, 390–393. [arXiv: quant-ph/9908010](https://arxiv.org/abs/quant-ph/9908010)
- Joyal, A., Street, R. and Verity, D. (1996) *Traced monoidal categories*. Proceedings of the Cambridge Philosophical Society **119**, 447–468.
- Kelly, G. M. and Laplaza, M. L. (1980) *Coherence for compact closed categories*. Journal of Pure and Applied Algebra **19**, 193–213.
- Seely, R. A. G. (1998) *Linear logic, \*-autonomous categories and cofree algebras*. Categories in Computer Science and Logic, Contemporary Mathematics **92**, 371–382.
- von Neumann, J. (1932) *Mathematische Grundlagen der Quantenmechanik*. Springer-Verlag. English translation (1955): *Mathematical Foundations of Quantum Mechanics*. Princeton University Press.
- Żukowski, M., Zeilinger, A., Horne, M. A. and Ekert, A. K. (1993) *‘Event-ready-detectors’ Bell experiment via entanglement swapping*. Physical Review Letters **71**, 4287–4290.

*Oxford University Computing Laboratory,  
Wolfson Building, Parks Road, Oxford, OX1 3QD, UK.*

Email: [abramsky@comlab.ox.ac.uk](mailto:abramsky@comlab.ox.ac.uk)  
[coecke@comlab.ox.ac.uk](mailto:coecke@comlab.ox.ac.uk)

This article may be accessed via WWW at <http://www.tac.mta.ca/tac/> or by anonymous ftp at <ftp://ftp.tac.mta.ca/pub/tac/html/volumes/14/6/14-06.{dvi,ps}>

THEORY AND APPLICATIONS OF CATEGORIES (ISSN 1201-561X) will disseminate articles that significantly advance the study of categorical algebra or methods, or that make significant new contributions to mathematical science using categorical methods. The scope of the journal includes: all areas of pure category theory, including higher dimensional categories; applications of category theory to algebra, geometry and topology and other areas of mathematics; applications of category theory to computer science, physics and other mathematical sciences; contributions to scientific knowledge that make use of categorical methods.

Articles appearing in the journal have been carefully and critically refereed under the responsibility of members of the Editorial Board. Only papers judged to be both significant and excellent are accepted for publication.

The method of distribution of the journal is via the Internet tools `WWW/ftp`. The journal is archived electronically and in printed paper format.

**SUBSCRIPTION INFORMATION.** Individual subscribers receive (by e-mail) abstracts of articles as they are published. Full text of published articles is available in .dvi, Postscript and PDF. Details will be e-mailed to new subscribers. To subscribe, send e-mail to `tac@mta.ca` including a full name and postal address. For institutional subscription, send enquiries to the Managing Editor.

**INFORMATION FOR AUTHORS.** The typesetting language of the journal is  $\text{\TeX}$ , and  $\text{\LaTeX}2\text{e}$  is the preferred flavour.  $\text{\TeX}$  source of articles for publication should be submitted by e-mail directly to an appropriate Editor. They are listed below. Please obtain detailed information on submission format and style files from the journal's WWW server at `http://www.tac.mta.ca/tac/`. You may also write to `tac@mta.ca` to receive details by e-mail.

**MANAGING EDITOR.** Robert Rosebrugh, Mount Allison University: `rrosebrugh@mta.ca`

**$\text{\TeX}$  NICAL EDITOR.** Michael Barr, McGill University: `mbarr@barrs.org`

**TRANSMITTING EDITORS.**

Richard Blute, Université d' Ottawa: `rblute@mathstat.uottawa.ca`

Lawrence Breen, Université de Paris 13: `breen@math.univ-paris13.fr`

Ronald Brown, University of North Wales: `r.brown@bangor.ac.uk`

Jean-Luc Brylinski, Pennsylvania State University: `jlb@math.psu.edu`

Aurelio Carboni, Università dell' Insubria: `aurelio.carboni@uninsubria.it`

Valeria de Paiva, Xerox Palo Alto Research Center: `paiva@parc.xerox.com`

Ezra Getzler, Northwestern University: `getzler(at)math(dot)northwestern(dot)edu`

Martin Hyland, University of Cambridge: `M.Hyland@dpms.cam.ac.uk`

P. T. Johnstone, University of Cambridge: `ptj@dpms.cam.ac.uk`

G. Max Kelly, University of Sydney: `maxk@maths.usyd.edu.au`

Anders Kock, University of Aarhus: `kock@imf.au.dk`

Stephen Lack, University of Western Sydney: `s.lack@uws.edu.au`

F. William Lawvere, State University of New York at Buffalo: `wlawvere@acsu.buffalo.edu`

Jean-Louis Loday, Université de Strasbourg: `loday@math.u-strasbg.fr`

Ieke Moerdijk, University of Utrecht: `moerdijk@math.uu.nl`

Susan Niefield, Union College: `niefiels@union.edu`

Robert Paré, Dalhousie University: `pare@mathstat.dal.ca`

Jiri Rosicky, Masaryk University: `rosicky@math.muni.cz`

Brooke Shipley, University of Illinois at Chicago: `bshipley@math.uic.edu`

James Stasheff, University of North Carolina: `jds@math.unc.edu`

Ross Street, Macquarie University: `street@math.mq.edu.au`

Walter Tholen, York University: `tholen@mathstat.yorku.ca`

Myles Tierney, Rutgers University: `tierney@math.rutgers.edu`

Robert F. C. Walters, University of Insubria: `robert.walters@uninsubria.it`

R. J. Wood, Dalhousie University: `rjwood@mathstat.dal.ca`